



Bulletin MSG11-5715-691/UK

## Operating instructions

Series

D31DW\*EE, D31NW\*EE,  
D\*1VW\*EE

Design series 93

II 2 G c T4 Gb

-20 °C < T<sub>a</sub> < +60 °C

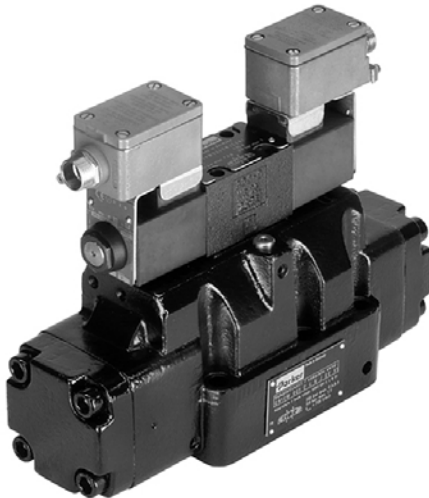

## Pilot Operated Proportional DC Valve

**Parker Hannifin**

**Manufacturing Germany GmbH & Co. KG**

Industrial Systems Division Europe

Gutenbergstr. 38

41564 Kaarst, Germany

E-mail: [isde.kaarst.support@support.parker.com](mailto:isde.kaarst.support@support.parker.com)

Copyright © 2022, Parker Hannifin Corp.



## **WARNING — USER RESPONSIBILITY**

**FAILURE OR IMPROPER SELECTION OR IMPROPER USE OF THE PRODUCTS DESCRIBED HEREIN OR RELATED ITEMS CAN CAUSE DEATH, PERSONAL INJURY AND PROPERTY DAMAGE.**

This document and other information from Parker-Hannifin Corporation, its subsidiaries and authorized distributors provide product or system options for further investigation by users having technical expertise.

The user, through its own analysis and testing, is solely responsible for making the final selection of the system and components and assuring that all performance, endurance, maintenance, safety and warning requirements of the application are met. The user must analyze all aspects of the application, follow applicable industry standards, and follow the information concerning the product in the current product catalog and in any other materials provided from Parker or its subsidiaries or authorized distributors.

To the extent that Parker or its subsidiaries or authorized distributors provide component or system options based upon data or specifications provided by the user, the user is responsible for determining that such data and specifications are suitable and sufficient for all applications and reasonably foreseeable uses of the components or systems.

<b>Contents</b>	<b>Page</b>
<b>0. EC declaration of conformity</b>	<b>4</b>
<b>1. Introduction</b>	<b>6</b>
Ordering code	7
Technical data	9
Characteristic curves	10
Pilot oil	12
Dimensions	13
Name plate	16
<b>2. Safety instructions</b>	<b>16</b>
Symbols	16
Marking, name plates	16
Work on the valve	16
<b>3. Important information</b>	<b>17</b>
Correct use	17
Common instructions	17
Liability	17
Storage	17
<b>4. Installation</b>	<b>18</b>
Scope of delivery	18
Installation	18
Electrical connection	18
Operation limits	18
Pressure fluids	18
<b>5. Operating instructions</b>	<b>21</b>
Air bleeding of hydraulic system	21
Filter	21
Flushing	21
<b>6. Maintenance</b>	<b>21</b>
Replacement of a coil	21
<b>7. Troubleshooting</b>	<b>23</b>
<b>A1 Extract from standards/directives</b>	<b>24</b>
<b>A2 User guide – Solenoid</b>	<b>25</b>
<b>A3 Type-examination certificate – Solenoid</b>	<b>29</b>
<b>A4 Declaration of conformity - Solenoid</b>	<b>43</b>
<b>A5 Mounting instruction cable gland</b>	<b>44</b>

## 0. EC declaration of conformity

EG-Konformitätserklärung / EC-Declaration of Conformity  
2014/34/EU (ATEX)



**Parker Hannifin Manufacturing Germany GmbH & Co. KG**  
Hydraulic Controls Division Europe  
Gutenbergstrasse 38  
41564 Kaarst, Germany

Parker Hannifin erklärt, dass die nachstehenden Produkte auf Seite 2 explosionsgeschützt ausgeführte Geräte im Sinne des Artikels 1 (3) der Richtlinie 2014/34/EU sind und die grundlegenden Sicherheits- und Gesundheitsanforderungen gemäß Anhang II dieser Richtlinie erfüllen.

Parker Hannifin declares, that series on page 2 are explosion-protected components according to article 1 (3) of directive 2014/34/EU and they fulfill the basic health and safety requirements specified in Annex II of this directive.

Folgende harmonisierte Normen wurden angewandt – weitere Hinweise zur Konformitätsaussage enthält die technische Dokumentation:

Below harmonised standards used – the technical documentation covers additional information regarding declaration of conformity:

- |                  |   |
|------------------|---|
| EN 1127-1:2011   | Explosionsfähige Atmosphären – Explosionsschutz<br>Teil 1: Grundlagen und Methodik<br>Explosive atmospheres - Explosion prevention and protection - Part 1: Basic concepts and methodology  |
| EN ISO 4413:2010 | Fluidtechnik – Allgemeine Regeln und sicherheitstechnische Anforderungen an Hydraulikanlagen und deren Bauteile<br>Hydraulic fluid power - General rules and safety requirements for systems and their components   |
| EN 13463-1:2009  | Nicht-elektrische Geräte für den Einsatz in explosionsgefährdeten Bereichen<br>Teil 1: Grundlagen und Anforderungen<br>Non-electrical equipment for use in potentially explosive atmospheres - Part 1: Basic method and requirements                                |
| EN 13463-5:2011  | Nicht-elektrische Geräte für den Einsatz in explosionsgefährdeten Bereichen<br>Teil 5: Schutz durch konstruktive Sicherheit "c"<br>Non-electrical equipment intended for use in potentially explosive atmospheres - Part 5: Protection by constructional safety "c" |

Die Geräte erfüllen die Anforderungen entsprechend der Kategorie / Angaben zur Kennzeichnung (Typenschild):  
The components fulfill the requirements of category / identification marking (on nameplate):



Der korrekte Gebrauch der Geräte bei Installation und Betrieb wird vorausgesetzt. Details zum korrekten Gebrauch (einschließlich Explosionsschutz) sind in der Betriebsanleitung hinterlegt.  
It is mandatory, that the installation and the operation of the components are according to their designated usage. Information to the designated use are given in installation manual and product documentation.

Die beschriebenen Produkte sind in Übereinstimmung mit den einschlägigen EU-Harmonisierungsvorschriften: Richtlinie 94/9/EG (bis 19. April 2016) und Richtlinie 2014/34/EU (ab 20. April 2016).  
The products of the declaration described are in conformity with the relevant Union harmonisation legislation: Directive 94/9/EC (until 19 April 2016) and Directive 2014/34/EU (from 20 April 2016).

Ort, Datum / Place, date:

Kaarst, 20.04.2016

Unterschrift / Signature:

Angaben zum Unterzeichner / Name and position:

  
Hansgeorg Kolvenbach / General Manager

2014-34-eu\_Wege-G-60\_20-04-16\_Fu

## EG-Konformitätserklärung / EC-Declaration of Conformity 2014/34/EU (ATEX)

Nachstehend alle Produkte, die den Anforderungen der Richtlinie entsprechen:  
Products that correspond fulfill to the requirements of directive:

1. **Vorgesteuerte Proportional-Wegeventile / pilot operated proportional DC valves**
  - D31FB\*EE-XG371
  - D41FB\*EE-XG371
  - D91FB\*EE-XG371
  - D111FB\*EE-XG371
2. **Direktgesteuerte Proportional-Wegeventile / direct operated proportional DC valves**
  - D1FB\*0EE-XG371
  - D1FB\*3EE-XG371
3. **Vorgesteuerte Wegeventile / pilot operated DC valves**
  - D31DW\*EE
  - D31NW\*EE
  - D41VW\*EE
  - D81/91VW\*EE
  - D111VW\*EE
4. **Direktgesteuerte Wegeventile / direct operated DC valves**
  - D1VW\*EE
5. **Proportional Druckreduzierventile / proportional pressure reducing valves**
  - D1FV\*EE-XG371

2014-34-eu\_Wege-G-60\_20-04-16\_Fu

## Operating Instructions

### 1. Introduction

The D\*1\*W\*EE with explosion proof solenoids are based on the standard D\*1\*W series. The specific solenoid design allows the usage in hazardous environments.

The explosion proof class is

CE (Ex) II 2 G  
Ex e mb IIC T4 Gb

for use in zone 1 and 2 (according to ATEX).

Additionally the solenoids are IECEx compliant.

All explosion proof solenoids are DC design. The valves for AC operate with integrated rectifier.

The pilot operated valves are available in 4 sizes:

D31DW NG10 (standard)

D31NW NG10 (high flow)

D41VW NG16

D91VW NG25 (for port diameter up to 32 mm)

D111VW NG32

All valves are piloted by a D1VW valve. The minimum pilot pressure must be ensured for all operating conditions of the directional valve.

Additionally spools with a P to T connection in the de-energized position need an external pressure supply (external inlet) or an integral check valve.

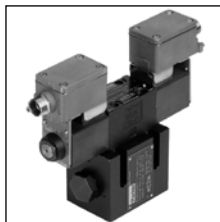

D31DW

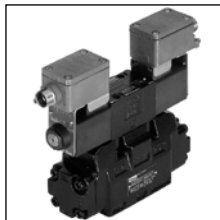
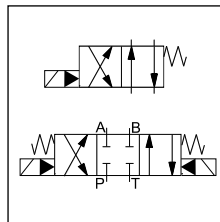

D31NW

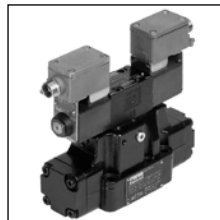

D41VW

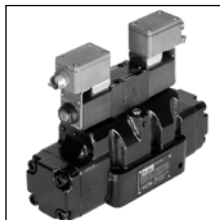

D91VW

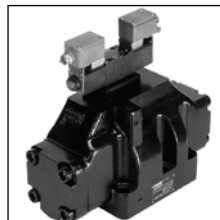

D111VW

### D91VW

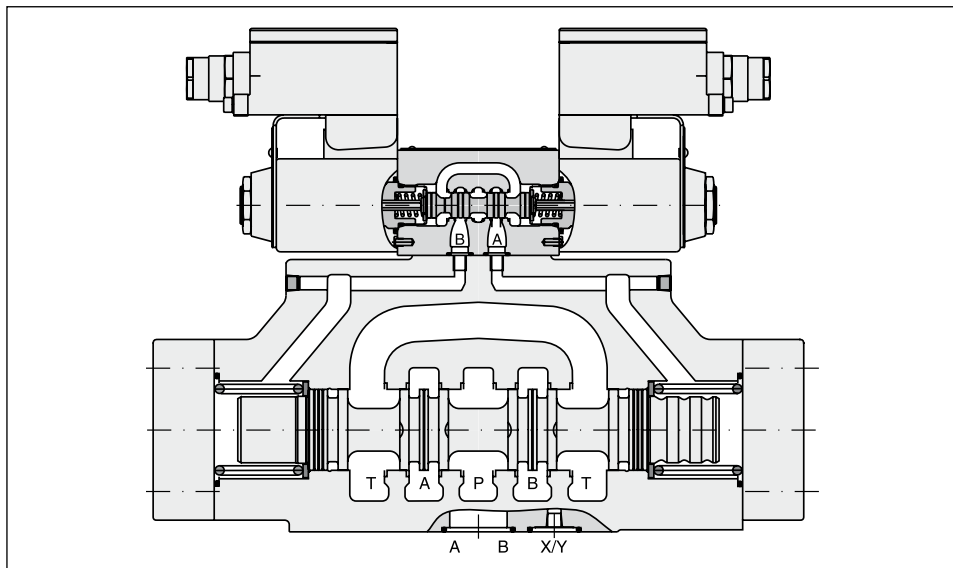

# Operating Instructions

# Pilot Operated Proportional DC Valve Series D\*W\*EE Explosion Proof

## Technical data

General					
Design		Directional spool valve			
Actuation		Solenoid			
Series		D31DW	D31NW	D41VW	D91VW D111VW
Size		NG10	NG10	NG16	NG25 NG32
Weight (1/2 solenoids)	[kg]	6.0 / 6.6	7.6 / 8.1	9.7 / 10.3	17.9 / 18.6 67.4 / 68.0
Mounting interface		DIN 24340	DIN 24340	DIN 24340	DIN 24340 DIN 24340
		A10	A10	A16	A25 A32
		ISO 4401	ISO 4401	ISO 4401	ISO 4401 ISO 4401
		NFPA D05	NFPA D05	NFPA D07	NFPA D08 NFPA D10
CETOP RP 121-H					
Mounting position		unrestricted, preferably horizontal			
Ambient temperature		-20...+60			
MTTF <sub>a</sub> value		[years] 75			
Hydraulic					
Max. operating pressure		[bar] P, A, B: 350; T: 210			
Fluid		Hydraulic oil according to DIN 51524			
Fluid temperature		[°C] -25 ... +60			
Viscosity permitted		[cSt] / [mm <sup>2</sup> /s] 2.8...400			
Viscosity recommended		[cSt] / [mm <sup>2</sup> /s] 30...80			
Filtration		ISO 4406 (1999); 18/16/13			
Flow max.		150	170	300	700 2000
Leakage at 350 bar (per flow path)		up to 100*	up to 150*	up to 200*	up to 800* up to 5000*
		*depending on spool			
Opening pressure integral check valve		[bar] n.a.	see p/Q diagram	see p/Q diagram	see p/Q diagram n.a.
Minimum pilot supply pressure		[bar] 5	7		5
Static / Dynamic					
Step response at 95 %		[ms] Energized / De-energized			
DC solenoids Pilot pressure		50 bar			
		100 bar	60 / 40 (50/60)	95 / 65	150 / 170 470 / 390
		250 bar	55 / 40 (50/60)	75 / 65	110 / 170 320 / 390
		350 bar	55 / 40 (50/50)	60 / 65	90 / 170 210 / 390
AC solenoids Pilot pressure		50 bar	55 / 40 (50/50)	60 / 65	85 / 170 200 / 390
		100 bar	40 / 30 (30/50)	75 / 55	130 / 155 450 / 375
		250 bar	35 / 30 (30/50)	65 / 55	90 / 155 300 / 375
		350 bar	35 / 30 (30/50)	40 / 55	70 / 155 190 / 375
Electrical characteristics		35 / 30 (30/50)	40 / 55	65 / 155	180 / 375
Duty ratio		100 % ED; CAUTION: coil temperature up to 135 °C possible			
Protection class		Code CE (Ex) II 2 G, Ex e mb IIC T4 Gb, IP66 (plugged and mounted correctly)			
Supply voltage / ripple		[V] 24 V =	N	P	
Tolerance supply voltage		[%] ±10	230/50 Hz	110/50 Hz	
Current consumption		[A] 1.0	±10	±10	
Power consumption		[W] 24	1.0	0.12	0.25
Solenoid connection		[W] 24	24	24	
Wiring min.		[mm <sup>2</sup> ] 3 x 1.5 recommended	Box with M20x1.5 entry for cable glands. Solenoid identification as per ISO 9461.		
Wiring length max.		[m] 50 recommended			

With electrical connections the protective conductor (PE ⊥) must be connected according to the relevant regulations.

# Operating Instructions

# Pilot Operated Proportional DC Valve Series D\*W\*EE Explosion Proof

## Ordering code



Series



Spool type



Spool position

Code	Bore	Size	Feature
D31DW	Ø11mm	NG10	
D31NW	Ø11mm	NG10	High flow
D41VW	Ø20mm	NG16	
D91VW	Ø32mm	NG25	
D111VW	Ø50mm	NG32	

3 position spool	
Code	Spool type
	a 0 b
001 <sup>2)</sup>	
002 <sup>2)</sup>	
003 <sup>3)</sup>	
004 <sup>3)</sup>	
005 <sup>3)</sup>	
006 <sup>3)</sup>	
009 <sup>1)2)</sup>	
011 <sup>3)</sup>	
015 <sup>3)</sup>	
016 <sup>3)</sup>	
021 <sup>3)</sup>	
022 <sup>3)</sup>	

2 position spool	
Code	Spool type
	a b
020 <sup>2)</sup>	
030 <sup>2)</sup>	

3 position spool		
Code	Spool position	
C <sup>2)</sup>		
	<b>3 positions.</b> Spring offset in position "0". Operated in position "a" or "b".	
	Standard	Spool type 009
E <sup>2)</sup>	 Operated in position "a".	 Operated in position "b".
	2 positions. Spring offset in position "0".	
F <sup>2)</sup>	 Spring offset in position "b".	 Spring offset in position "a".
	2 positions. Operated in position "0".	
K <sup>2)</sup>	 Operated in position "b".	 Operated in position "a".
	2 positions. Spring offset in position "0".	
M <sup>2)</sup>	 Spring offset in position "a".	 Spring offset in position "b".
	2 positions. Operated in position "0".	
R <sup>3)4)</sup>	 No centre in offset position.	 No centre in offset position.
	2 positions, detent. Operated in position "0" or "b".	
S <sup>3)4)</sup>	 No centre in offset position.	 No centre in offset position.
	2 positions, detent. Operated in position "0" or "a".	

2 position spools		
Code	Spool position	
B <sup>2)</sup>		
	<b>Spring offset in position "b".</b> <b>Operated in position "a".</b>	
D <sup>3)4)</sup>	 No centre in offset position.	
	Detent, operated in position "a" or "b".	
H <sup>2)</sup>		
	Spring offset in position "a". Operated in position "b".	



# Operating Instructions

# Pilot Operated Proportional DC Valve Series D\*W\*EE Explosion Proof

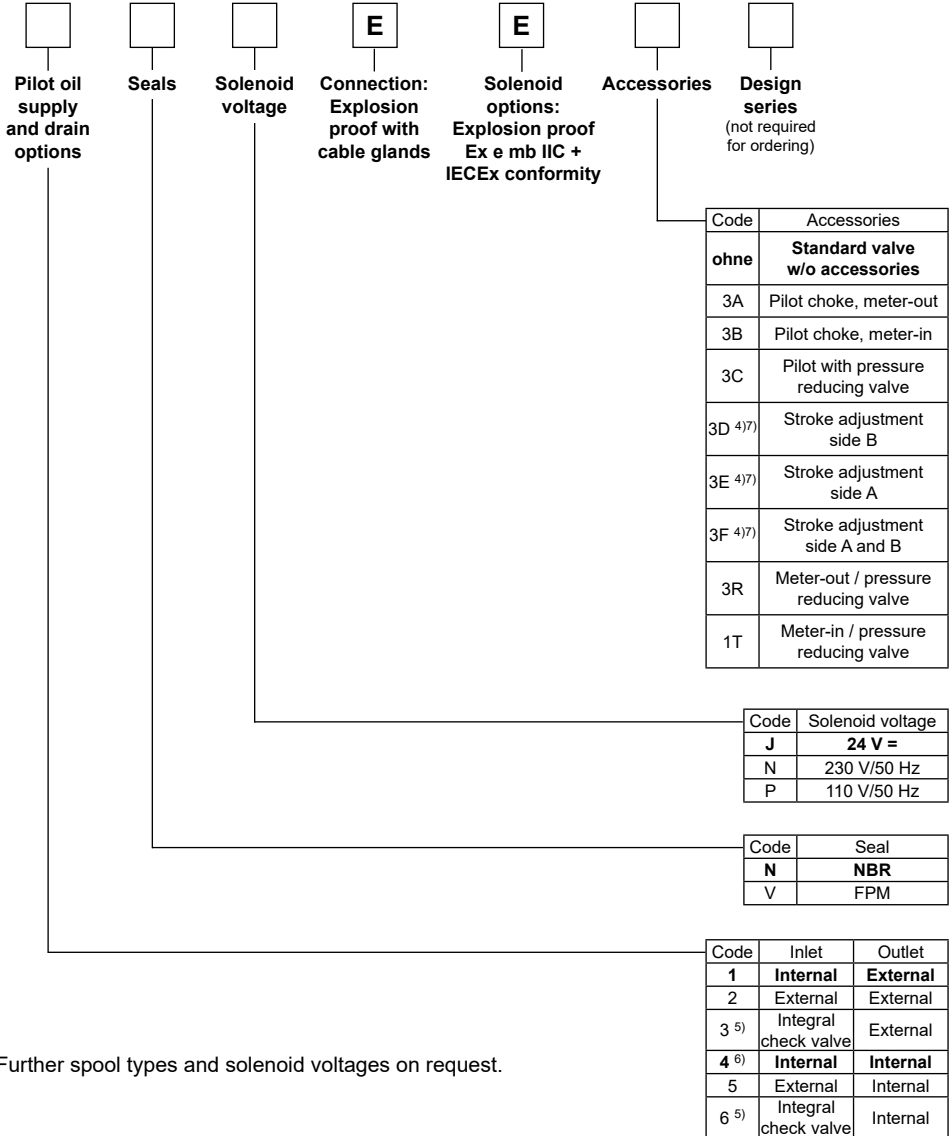

- 1) Consider specific spool position.
- 2) All sizes (D31, D41, D 91, D111) available
- 3) Only D31, D41, D91 available.
- 4) D31DW\*D/R/S is not available with accessories 3D, 3E or 3F.
- 5) Not for D31DW and D111VW available.
- 6) Not for spools 002, 009 and 030 available.
- 7) Only D31, D41, D91 available.

## Operating Instructions

### Flow curves

The flow curve diagram shows the flow versus pressure drop curves for all spool types. The relevant

curve number for each spool type, operating position and flow direction is given in the table below.

### D31DW and D41VW

Spool Code	Curve number									
	P-A		P-B		P-T		A-T		B-T	
	D3	D4	D3	D4	D3	D4	D3	D4	D3	D4
001	3	1	3	1	-	-	1	4	1	5
002	3	1	3	2	4	6	1	4	1	6
003	3	1	4	2	-	-	1	5	1	6
004	3	1	3	1	-	-	1	5	1	5
005	3	2	4	2	-	-	1	3	1	5
006	3	1	3	2	-	-	1	3	1	6
007	4	1	3	1	-	6	1	4	1	5
009	3	2	3	9	8	8	1	7	1	10
011	3	1	3	1	-	-	1	4	1	5
014	3	1	4	1	-	6	1	4	1	5
015	4	1	3	2	-	-	1	4	1	6
016	4	2	3	2	-	-	1	3	1	5
020	3	3	4	5	-	-	1	3	1	5
021	4	2	3	8	-	-	1	2	-	-
022	3	8	4	2	-	-	-	-	1	3
026	3	3	3	5	-	-	-	-	-	-
030	3	2	1	3	-	-	1	6	1	7
054	-	2	-	3	-	-	-	6	-	7

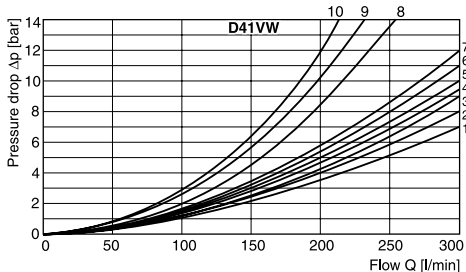
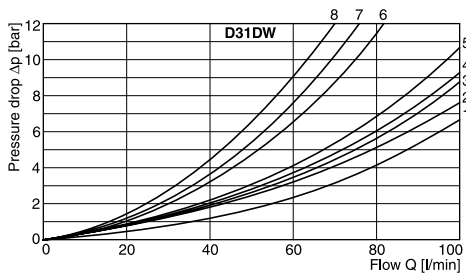

### D31NW

Spool Code	Curve number				
	P-A	P-B	P-T	A-T	B-T
001	3	3	-	2	5
002	3	3	7	4	3
003	2	3	-	4	4
004	2	3	-	4	4
005	2	4	-	1	4
006	8	9	-	7	9
009	4	6	6	4	10
011	3	3	-	2	4
015	2	2	-	1	4
016	4	3	-	2	4
020	6	4	-	3	6
021	-	7	-	8	-
022	4	-	-	9	-
030	5	3	-	2	5

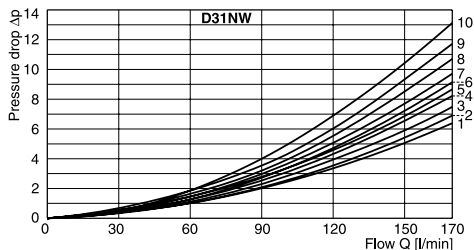

All characteristic curves measured with HLP46 at 50 °C.

## Operating Instructions

### Flow curves / Integral check valve D91VW and D111VW

Spool Code	Curve number									
	P-A		P-B		P-T		A-T		B-T	
	D9	D11	D9	D11	D9	D11	D9	D11	D9	D11
001	3	5	2	5	-	-	3	4	5	1
002	2	5	1	5	1	5	3	4	5	1
003	4	-	2	-	-	-	3	-	6	-
004	4	-	3	-	-	-	3	-	5	-
005	1	-	2	-	-	-	4	-	5	-
006	2	-	2	-	-	-	4	-	6	-
007	3	-	1	-	7	-	3	-	5	-
009	4	3	8	3	9	2	4	3	10	1
011	3	-	2	-	-	-	3	-	5	-
014	1	-	2	-	8	-	3	-	5	-
015	3	-	3	-	-	-	4	-	5	-
016	3	-	3	-	-	-	4	-	5	-
020	6	5	5	5	-	-	6	3	8	1
021	5	-	10	-	-	-	3	-	-	-
022	10	-	5	-	-	-	-	-	5	-
026	6	-	5	-	-	-	-	-	-	-
030	3	5	2	5	-	-	3	4	5	1
054	4	5	3	5	-	-	3	4	5	1

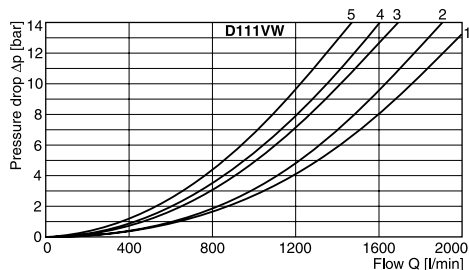
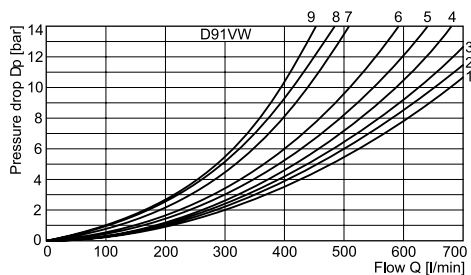

### Integral check valve in the P port

Mounting an integral check valve in the P port is necessary to build up pilot pressure for valves with P to T connection and internal pilot oil supply. The pressure difference at the integral check valve (see performance curves) is to be added to all flow curves of the P-port of the main valve. Directional valves with an integral check valve are available for the series D31NW and D41VW.

### Flow curve D41VW

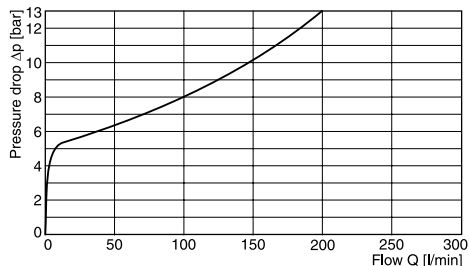

### Flow curve D31NW

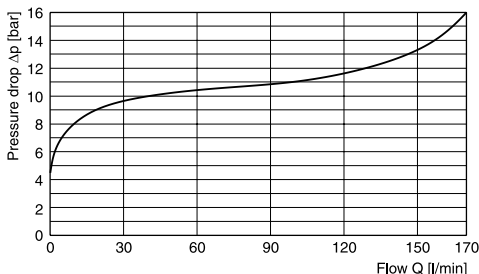

### Flow curve D91VW

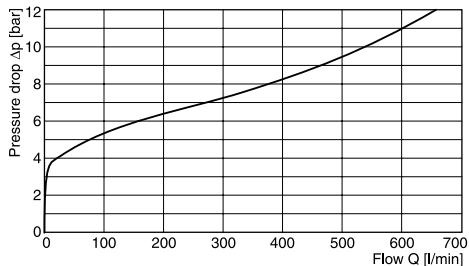

Operating Instructions

Pilot oil inlet (supply) and outlet (drain)  
D31DW

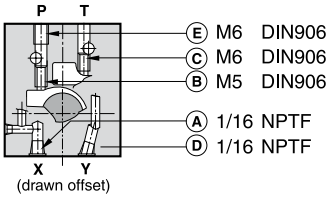

○ open, ● closed

Pilot oil		A	B	C	D	E
Inlet	Outlet					
internal	external	●	○	●	○	Orifice Ø1.2
external	external	○	●	●	○	Orifice Ø1.2
internal	internal	●	○	○	●	Orifice Ø1.2
external	internal	○	●	○	●	Orifice Ø1.2

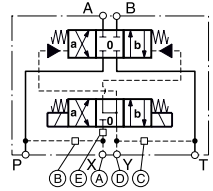

D31NW

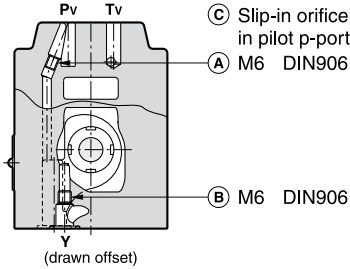

○ open, ● closed

Pilot oil		A	B	C
Inlet	Outlet			
internal	external	○	●	Orifice Ø1.0
external	external	●	●	Orifice Ø1.0
internal	internal	○	○	Orifice Ø1.0
external	internal	●	○	Orifice Ø1.0

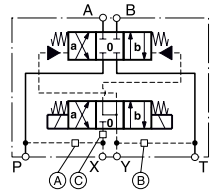

D41VW

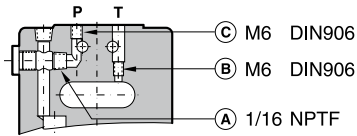

○ open, ● closed

Pilot oil		A	B	C
Inlet	Outlet			
internal	external	○	●	Orifice Ø1.5
external	external	●	●	Orifice Ø1.5
internal	internal	○	○	Orifice Ø1.5
external	internal	●	○	Orifice Ø1.5

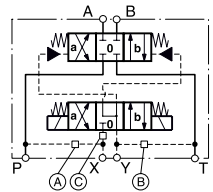

D91VW

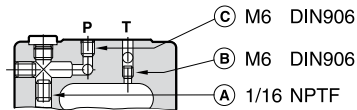

○ open, ● closed

Pilot oil		A	B	C
Inlet	Outlet			
internal	external	○	●	Orifice Ø1.5
external	external	●	●	Orifice Ø1.5
internal	internal	○	○	Orifice Ø1.5
external	internal	●	○	Orifice Ø1.5

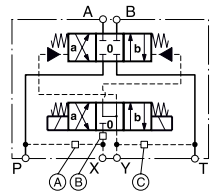

D111VW

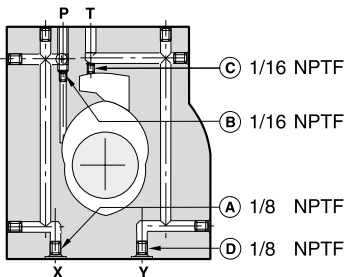

○ open, ● closed

Pilot oil		A	B	C	D
Inlet	Outlet				
internal	external	○	Orifice Ø1.5	●	○
external	external	Orifice Ø1.5	●	●	○
internal	internal	○	Orifice Ø1.5	○	○
external	internal	Orifice Ø1.5	●	○	○

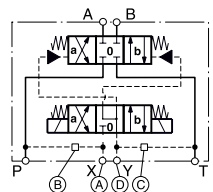





All orifice sizes for standard valves

# Operating Instructions

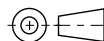
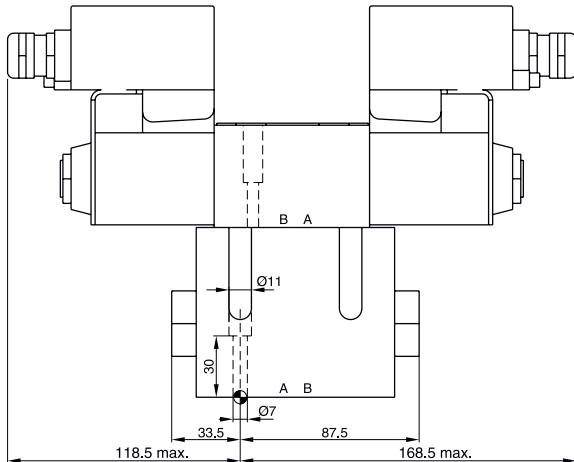
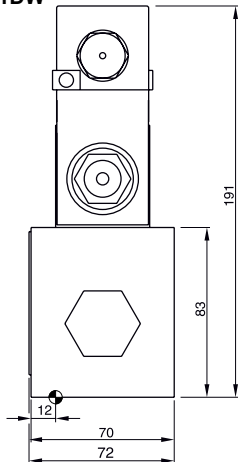
## Dimensions



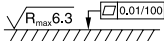

### D31DW

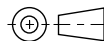
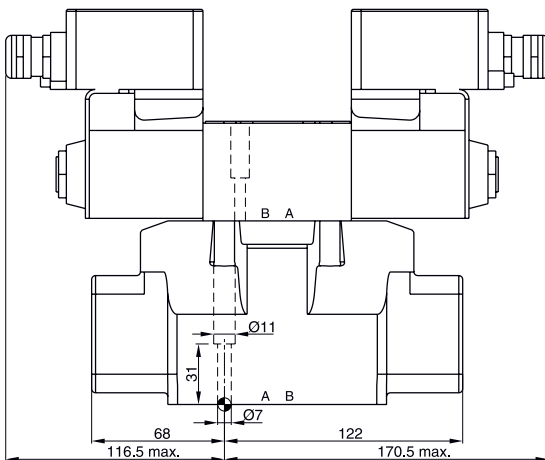
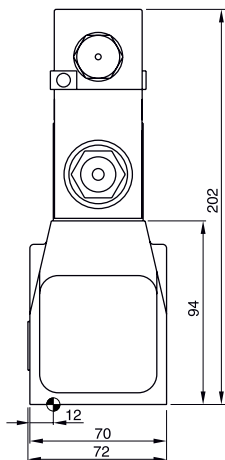

Surface finish	 Kit	 4x M6x40 ISO 4762-12.9	 13.2 Nm ±15 %	 Kit
	BK385			<b>NBR: SK-D31DW-N-91</b> FPM: SK-D31DW-V-91

### D31NW

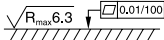

Surface finish	 Kit	 4x M6x40 ISO 4762-12.9	 13.2 Nm ±15 %	 Kit
	BK385			NBR: SK-4D02V-B1 FPM: SK-4D02V-B5

D\_W\_EE 5715-691 UK.indd 11.01.22

# Operating Instructions

# Pilot Operated Proportional DC Valve Series D\*W\*EE Explosion Proof

## D41VW

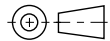
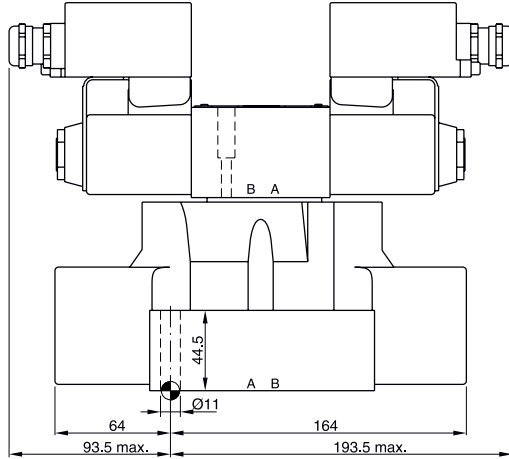
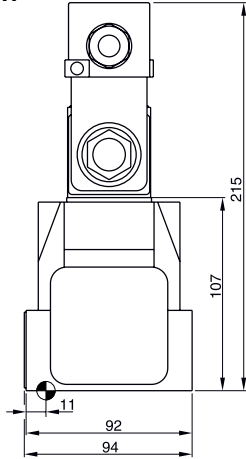

Surface finish	Kit	Kit	Kit	Kit
$\sqrt{R_{max} 6.3}$ $\square 0.01/100$	BK320	4x M10x60 2x M6x55 ISO 4762-12.9	63 Nm $\pm 15\%$ 13.2 Nm $\pm 15\%$	<b>NBR: SK-D41VW-N-91</b> FPM: SK-D41VW-V-91

## D91VW

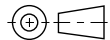
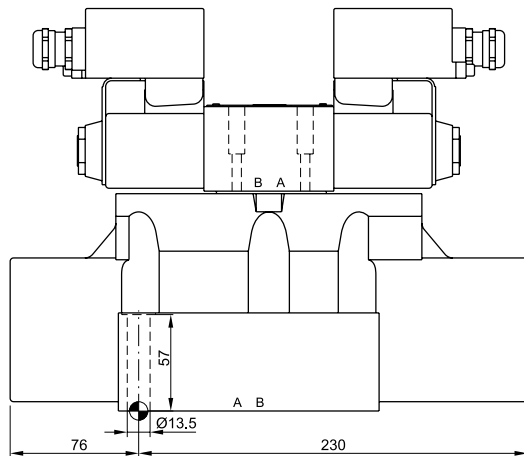
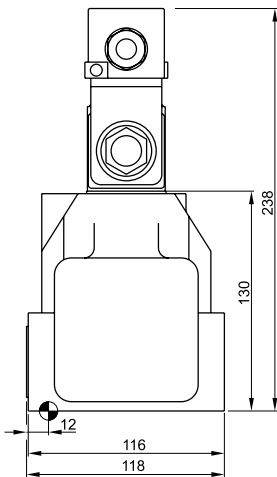

Surface finish	Kit	Kit	Kit	Kit
$\sqrt{R_{max} 6.3}$ $\square 0.01/100$	BK360	6x M12x75 ISO 4762-12.9	108 Nm $\pm 15\%$	<b>NBR: SK-D81VW-N-91 / SK-D91VW-N-91</b> FPM: SK-D81VW-V-91 / SK-D91VW-V-91





D\_W\_EE 5715-691 UK.indd 11.01.22

# Operating Instructions

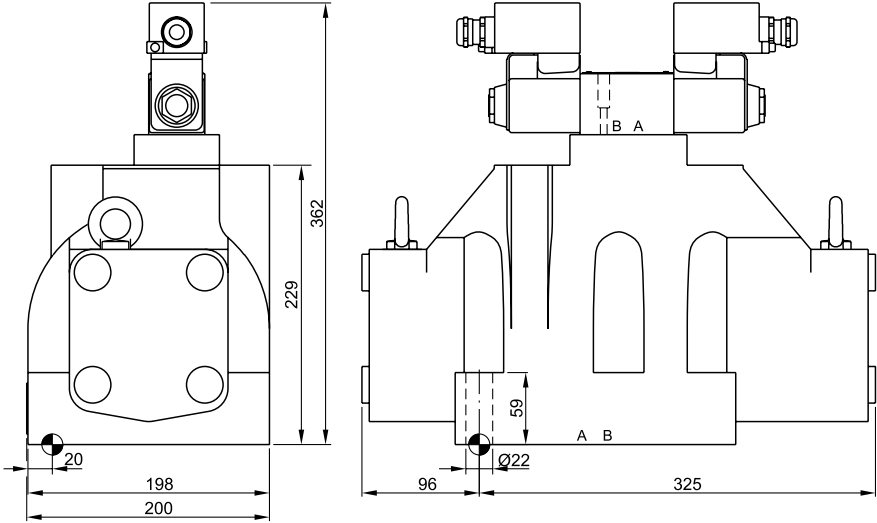
# Pilot Operated Proportional DC Valve Series D\*W\*EE Explosion Proof

D111VW

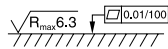

Surface finish	 Kit	 		 Kit
	BK386	6x M20x90 ISO 4762-12.9	517 Nm ±15 %	<b>NBR: SK-D111VW-N-91</b> FPM: SK-D111VW-V-91

## Operating Instructions

### Name plate

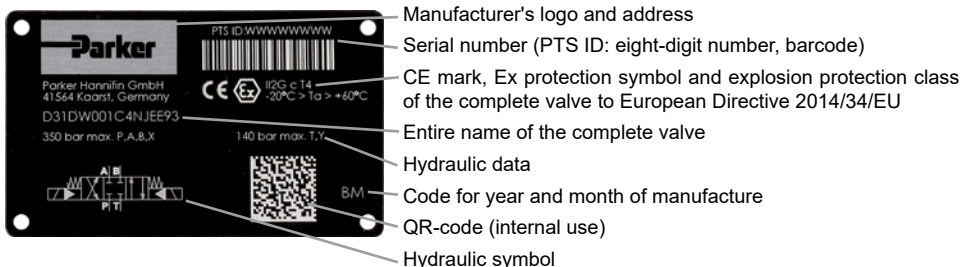

## 2. Safety instructions

Read the operating instructions thoroughly before installation, commissioning, maintenance, repair and storage, and observe them. Failure to observe the operating instructions may result in damage to the valve or the parts of the system connected to it. In particular, in the case of explosive atmospheres, any failure to observe the operating instructions may result in an explosion.

The system operator must make these operating instructions visible and easily accessible to operating and maintenance personnel.

Compliance with applicable standards/legal requirements must be enforced. This particularly applies to plant safety and environmental protection. A list of such standards, etc. appears in the annex by way of example.

Before starting commissioning, installation, maintenance and repair work, the hydraulic system must be depressurised and power must be disconnected from the electrical installation.

In addition, the electrical installation must be secured so that power cannot be restored unexpectedly.

The valve may become hot during operation. To avoid risk of burns, do not touch the valve surface. The system operator must monitor the temperature and cool the oil if necessary in order to the

keep within the maximum temperatures set out in these operating instructions (see technical data). In this connection, observe the relevant directions in the operating instructions of the supplier (solenoid system).

Any leaks occurring at the valve must be rectified immediately.

### Symbols

These instructions use symbols that must be noted according to their importance:



**Notes relating to the warranty**



**Notes relating to potential damage to the valve or connected system components**



**Notes relating to potential hazards**



**Useful additional information**

### Marking, Name plates

Information attached directly to the valve such as circuit plans and Name plates must be observed and kept in a legible state.



## Operating Instructions

### Work on the valve

Work relating to the installation, commissioning, maintenance and repair of the valve may only be carried out by qualified persons. Qualified persons are defined as persons who, on the basis of education, experience and instruction, have sufficient knowledge of applicable requirements and accepted rules of the technology.

Throughout any installation, commissioning, maintenance and repair work, it is the responsibility of the operator to ensure that there is no risk of explosion.

Before starting such work, the operator has to ensure that tools and equipment are only used if they do not damage the valve and they do not leave behind residues that are inflammable.

In addition, clean the valve before starting such work, in particular removing dust, liquids and other deposits. Cleaning should be done using a lint-free cloth.

Tools may not be used if they might cause a static charge on use.

### 3. Important information

#### Correct use

 These operating instructions apply to proportional DC valves of series D1VW\*EE, which are intended solely for use in mineral oil based hydraulic systems (DIN 51524).

Compliance with the operating instructions must be ensured.

It is the responsibility of the operator to ensure that the information in the technical data is followed.

Any different or modified use is not classed as correct use.

The manufacturer's warranty will not cover any resulting damage.

### Common instructions

We reserve the right to make technical changes as a result of further development of the product described in these operating instructions. Figures and drawings in these instructions are simplified depictions. As a result of further development, improvements and changes to the product, it is possible that the figures are not fully consistent with the described valve.

The technical details and dimensions are non-binding. They may not form the basis of any claims. Copyright reserved.

### Liability

The manufacturer cannot accept liability for loss or damage resulting from the following faults:

- incorrect installation
- unqualified operation
- inadequate maintenance
- use beyond specification

 Do not dismantle the valve. If you suspect a defect, return the valve to Parker.

### Storage

If the valve needs to be temporarily stored, it must be protected from dirt, the weather, and mechanical damage. Each valve is tested with hydraulic oil in the factory, so that the internal components are protected from corrosion. However, this protection can only be guaranteed under the following conditions:

Storage time	Storage requirements
12 months	constant air humidity < 60 % constant temperature < 25 °C
6 months	varying air humidity, varying temperature < 35 °C

 Storage outside or in maritime or tropical climates leads to corrosion and may make the valve unusable.

## Operating Instructions

### 4. Installation

#### Scope of delivery

As soon as you receive the valve you should check if the package has the specified contents. In particular, check whether the type of protection indicated on the valve is as described in these operating instructions.

The scope of delivery includes:

- Valve
- Operating instructions (including operating instructions of the valve as well as of the solenoid and the declarations of conformity of the manufactures)

 As soon as you receive the shipment, please check for any obvious signs of damage caused by careless transport. Document the transport damage and immediately notify the carrier, the insurance company and the supplier.

#### Installation

- Compare the valve type as stated on the Name plate with the parts list/circuit diagram.
- The valve can be installed in any position, either fixed or movable.

 Check the fixing surface and the cavity for the valve. Permitted values: unevenness 0.01 mm/100 mm, roughness  $R_{max} = 6.3 \mu m$ . Keep the valve mounting surface and the area clean.

- Before installation, remove the protective cover from the valve ports.
- Check that the valve ports and the O-rings are in the correct position.
- Use fastening screws as indicated in the catalogue, property class 12.9 to ISO 4762.

 Parker can supply the correct screw sets, see the catalogue for order numbers.

- Tighten the screws diagonally, torque as specified in the catalogue.
- Any deficiencies of the valve mounting surface may result in operating disruptions. Faulty fixing and incorrect screw tightening torques may lead to the sudden escape of hydraulic fluid at the ports.
- The valve must be connected to the equipotential bonding system of the hydraulic system.

#### Electrical connection

Observe operating instructions D14-2128D3-\* and K14-2074D3-\* in the annex.

#### Operation limits

The valve may only be deployed with the specified limits of use. The relevant details can be found in the catalogue sheet under "Technical data" and "Characteristic curves".



Observe the ambient conditions. Unauthorised temperatures, shocks, the effects of aggressive chemicals, radiation, unauthorised electromagnetic emissions may result in disruptions and failures. Observe the limits of operation set out in "Technical data".



Excessive temperatures may cause the solenoid to overheat, creating the risk of explosion. To permit adequate heat dissipation, the solenoid coil should not be painted.

#### Pressure fluids

The following rules applies for the operation with various pressure fluids:



This information serves for orientation and does not substitute user tests among the particular operating conditions. Particularly no liability for media compatibility may be derived out of it.

Mineral oil: usable without restriction.

For operation with the following pressure fluids please consult Parker:

HFA	oil-in-water emulsion
HFB	water-in-oil emulsion
HFC	aqueous solution (glycols)
HFD	unhydrous fluids (Phosphor-Ester)

 For detailed information concerning pressure fluids note VDMA-document 24317 as well as DIN 51524 & 51502.

Special gaskets may be available depending on the utilized fluid.

In case of insecurity please consult Parker.

The pressure fluid must have an ignition temperature of at least 50 K above the maximum surface temperature of the valve (see EN 13463-5 and IEC 60079-4).

# Operating Instructions

# Pilot Operated Proportional DC Valve Series D\*W\*EE Explosion Proof

Size 10, mounting pattern ISO 4401-05-05-0-05

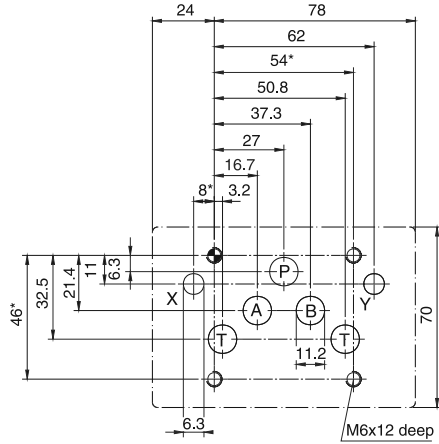

Deviating from ISO 4401  
these diameters are possible:  
X, Y =  $\varnothing$  8 max.

Size 16, mounting pattern ISO 4401-07-07-0-05

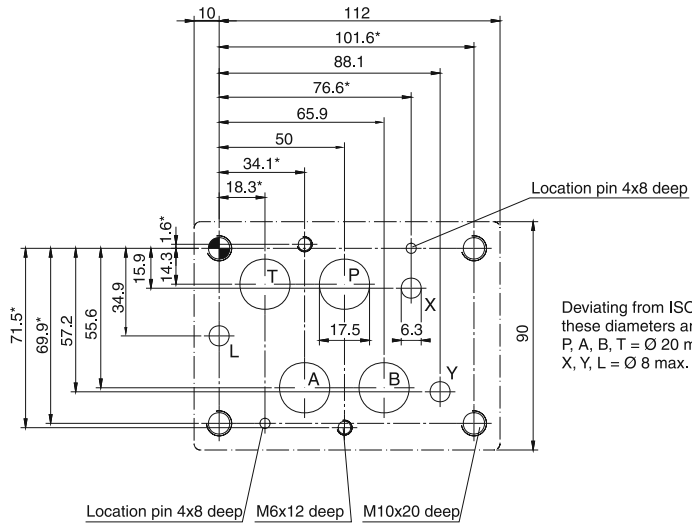

Deviating from ISO 4401  
these diameters are possible:  
P, A, B, T =  $\varnothing$  20 max.  
X, Y, L =  $\varnothing$  8 max.

With \* marked dimensions  $\pm 0.1$ mm.  
All other dimensions  $\pm 0.2$ mm.

D\_W\_EE 5715-691 UK.indd 11.01.22

# Operating Instructions

# Pilot Operated Proportional DC Valve Series D\*W\*EE Explosion Proof

## Size 25, mounting pattern ISO 4401-08-08-0-05

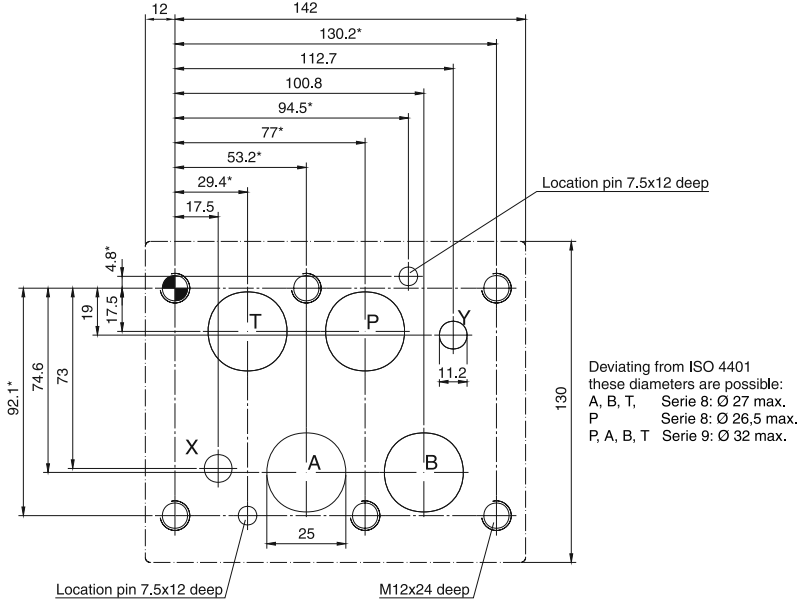

## Size 32, mounting pattern ISO 4401-10-09-0-05

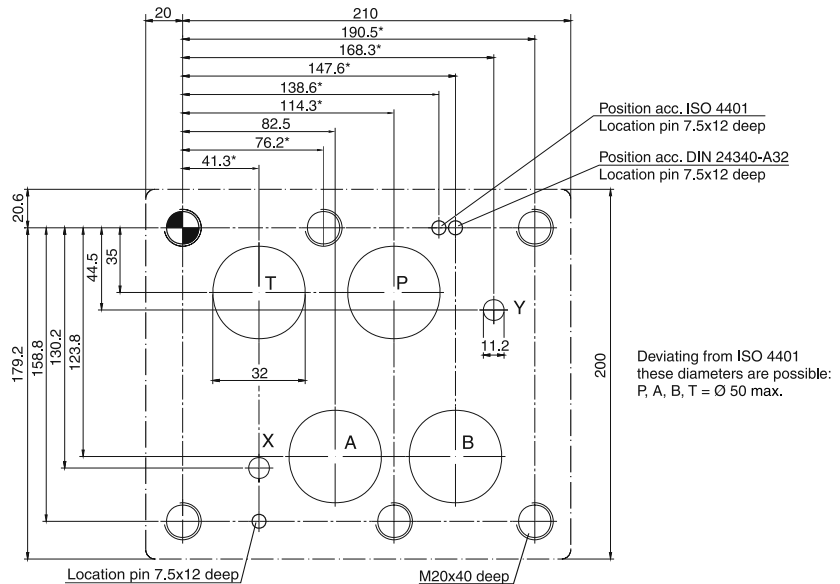

With \* marked dimensions  $\pm 0.1\text{mm}$ .  
 All other dimensions  $\pm 0.2\text{mm}$ .

D\_W\_EE 5715-691 UK.indd 11.01.22

## Operating Instructions

### 5. Operating instructions

#### Air bleeding of hydraulic system

During initial startup, after an oil change as well as after the opening of lines or valves the hydraulic system must be air bled.

#### Filter

The function and lifetime of the valve are strongly affected by the cleanliness of the fluid.

Purity level class of 18/16/13 acc. ISO4406 is required.

 Pay attention to maintenance details!

#### Flushing

It is recommended to flush the pipelines by short circuiting the pressure and return lines. This prevents the installation dirt from entering the valve.

### 6. Maintenance

 Maintenance procedures may only be carried out by specialist personnel. A detailed knowledge is required of how the machine is switched on and off and also of the necessary safety measures.

Regular maintenance is essential in prolonging the service life of the systems, and safeguards plant safety and operational availability. The following items must be checked at regular and short intervals:

- Oil level in tank
- Max. medium temperature
- Max. surface temperature
- Condition of the pressure fluid (sight check, colour and smell of hydraulic fluid)
- Operating pressures
- Preload pressure of pressure vessel (if present)
- No leaks at any system components
- Condition of the filter elements
- Condition of the hose lines
- Cleanliness of components

After a certain period of service, the hydraulic fluid must be replaced. The frequency of the change depends on the following circumstances:

- Type and grade of pressure fluid (ageing)
- Filtration
- Operating temperature and ambient conditions

#### Replacement of a coil

In case of a necessary replacement of a coil the disassembly and assembly instructions on drawing 35015707 (see next page) have to be observed. Before exchanging a coil the name plates of old and new coil have to be checked. It must be ensured that only coils with identical voltages are used.

Available coil kits are:

AK-D1VWCJEE93	24 V DC
AK-D1VWCKEE93	12 V DC
AK-D1VWCPEE93	110 V / 50 Hz
AK-D1VWCNEE93	230 V / 50 Hz

The coils of series 93 are suitable for valves of series 91 as well as 92 and 93.





## A1.

### Standards, directives and provisions relating to the operation of systems in potentially explosive areas (extract)

1999/92/EC	Minimum requirements for improving the safety and health protection of workers potentially at risk from explosive atmospheres
2004/108/EC	Electromagnetic compatibility directive (EMC)
EN ISO 12100:2010	Safety of machinery – General principles for design risk assessment and risk reduction
EN 15198:2007	Methodology for risk assessment of non-electrical equipment and components for intended use in potentially explosive atmospheres
EN 60079-0:2009	Explosive atmospheres – Part 0: Equipment – General requirements
EN 60079-7:2007	Explosive atmospheres – Part 7: Equipment protection by increased safety “e”
EN 60079-14:2009	Explosive atmospheres – Part 14: Electrical installations design, selection and erection (IEC 60079-14:2013)
EN 60079-17:2014	Explosive atmospheres – Part 17: Electrical installations inspection and maintenance (IEC 60079-17:2013)
EN 60529:2014	Degrees of protection provided by enclosures (IP code) (IEC 60529:1989 + A1:1999 + A2:2013)
BetrSichV	Ordinance on industrial safety and health
TRBS 2153:2009	Technical rules for operating safety Avoiding ignition hazards as a result of electrostatic charges



# Operating Instructions

# Pilot Operated Proportional DC Valve Series D\*W\*EE Explosion Proof

## A2. User guide – Solenoid

**REV. DESCRIPTION DATE APPR.**

1	SEE COM-123230000		
2	SEE COM-123230000		

**REVISIONS**

REV.	DESCRIPTION	DATE	APPR.
1	SEE COM-123230000		
2	SEE COM-123230000		

**REV. DESCRIPTION DATE APPR.**

1	SEE COM-123230000		
2	SEE COM-123230000		

**REV. DESCRIPTION DATE APPR.**

1	SEE COM-123230000		
2	SEE COM-123230000		

**REV. DESCRIPTION DATE APPR.**

1	SEE COM-123230000		
2	SEE COM-123230000		

**REV. DESCRIPTION DATE APPR.**

1	SEE COM-123230000		
2	SEE COM-123230000		

**PART NUMBER: D14-212803-\***

**COVER MOUNTED WITH TORQUE: 2.0 ± 0.30 Nm**

**3X 14.86 ± 0.14 88 (10.585 ± 0.5901)**

**3X 19.31 ± 0.14 43 (10.766 ± 0.7651)**

**22.67 (10.9831) NOMINAL**

**45.76 (1.765) NOMINAL**

**16.34 (0.643) NOMINAL**

**22.20 ± 0.22 40 (0.874 ± 0.8821)**

**57.91 (2.280) NOMINAL**

**71.59 (2.819) NOMINAL**

**3X 3M INT. PROTR. ON SLOTS: WIDTH = 4.31 ± 0.10 (0.169 ± 0.010) DEPTH = 1.52 ± 0.10 (0.060 ± 0.010) WITHIN 1° CENTERLINE**

**SECTION A-A SCALE 0.600**

**INTERNAL WIRING DIAGRAM**

**TEMP. CLASS**

TEMP. CLASS	FORCE (N) ± 0.04
1	16.8
2	24.0
3	32.0
4	40.0
5	48.0
6	56.0
7	64.0
8	72.0
9	80.0
10	88.0
11	96.0
12	104.0
13	112.0
14	120.0
15	128.0
16	136.0
17	144.0
18	152.0
19	160.0
20	168.0

**COIL SIZE CHART**

COIL SIZE	A	B	C	D	E	F
2	16.34	14.86	14.86	14.86	14.86	14.86
3	19.31	17.83	17.83	17.83	17.83	17.83
4	22.20	20.80	20.80	20.80	20.80	20.80
5	25.10	23.77	23.77	23.77	23.77	23.77
6	28.00	26.74	26.74	26.74	26.74	26.74
7	30.90	29.71	29.71	29.71	29.71	29.71
8	33.80	32.68	32.68	32.68	32.68	32.68
9	36.70	35.65	35.65	35.65	35.65	35.65
10	39.60	38.62	38.62	38.62	38.62	38.62
11	42.50	41.59	41.59	41.59	41.59	41.59
12	45.40	44.56	44.56	44.56	44.56	44.56
13	48.30	47.53	47.53	47.53	47.53	47.53
14	51.20	50.50	50.50	50.50	50.50	50.50
15	54.10	53.47	53.47	53.47	53.47	53.47
16	57.00	56.44	56.44	56.44	56.44	56.44
17	59.90	59.41	59.41	59.41	59.41	59.41
18	62.80	62.38	62.38	62.38	62.38	62.38
19	65.70	65.35	65.35	65.35	65.35	65.35
20	68.60	68.32	68.32	68.32	68.32	68.32

**COIL**

**PART No. D14-212803-\***

**SIZE SCALE: 1:000 SHEET NO. 6**

**3rd ANGLE PROJECTION**

**mm (inch)**

**BEZ**

**DESCRIPTION**

**ITEM PART NUMBER DESCRIPTION QTY.**

1	H4901	NUT	1
2	H1102	SPACER	1
3	MOR20022R2	O-RING	1
4	H-23886-*	COIL ASSEMBLY	1

**COIL**

**PART No. D14-212803-\***

**SIZE SCALE: 1:000 SHEET NO. 6**

**3rd ANGLE PROJECTION**

**mm (inch)**

**BEZ**

**DESCRIPTION**

**ITEM PART NUMBER DESCRIPTION QTY.**

1	H4901	NUT	1
2	H1102	SPACER	1
3	MOR20022R2	O-RING	1
4	H-23886-*	COIL ASSEMBLY	1

**DRAWN BY: D. HANNIFIN 11-Mar-14**

**CHECKED BY: R. DEWITT 10-Mar-14**

**APPROVED BY: T.G. GEMMAY 14-Mar-14**

**NO. OF COPIES OF THIS DRAWING: 100**

**NO. OF COPIES OF THE RECEIVED DRAWING: 100**

**PROJECT NUMBER: 11400011**

**Manufacturer: LISK Ireland Limited**  
Tel: +353 (0)91 831711  
NY 14432, USA

**NOTES**

- DUTY : CONTINUOUS
- MAX. STABILIZED WATTS RELATES TO STABILIZED POWER CONSUMPTION AT THE MAXIMUM AMBIENT TEMPERATURE. WATTS @ 25°C RELATES TO THE POWER CONSUMPTION THIN FILLED TO A COIL AND AMBIENT TEMPERATURE OF 25°C.
- FORCE SPRING @ 3.0mm (0.118in) STROKE @ NOMINAL VOLTAGE @ 25°C (11F)
- CABLE ENTRY USING D14-2088 OR D14-2089 USE.
- USE IN CONJUNCTION WITH SUB CIRCUIT FUSE BS88, IEC269, 6A MAX (DC).
- DO NOT OPEN TERMINAL BOX WHILE ENERGISED.
- ELECTROSTATIC RISK. CLEAN OIL WITH A DAMP CLOTH.
- SUBSTITUTION OF ANY COIL COMPONENTS (INCLUDING ALL FASTENERS) NOT SPECIFIED BY LISK MAY VOID CERTIFICATION.

**EXTERNAL ENTRY ASSEMBLY**

**CLAMP MAT. 8.1 ± 0.05mm TORQUE: 1.5 ± 0.1 Nm**

**INTERNAL EARTH GROUNDING**

**SEE A PLACE INTERNAL EARTH STRAP AND NOT OVERLAPSED STRAP NOT AND OVERLAPSED TORQUE: 1.2 ± 0.1 Nm**

**TERMINAL BOX COVER MOUNTING**

**DO NOT OPEN TERMINAL BOX WITHOUT THE APPROVAL OF CPA. T.G. 19 MAY 14**

**HEAT-SINK TO BE CAST IRON/STEEL**

**SEE COIL SIZE CHART FOR SUBMOUNTING**

**MAXIMUM FORCE TO BE APPLIED TO VALVE BODY WITH CLEANANCE FOR A SLIP FIT**

**COIL SIZE: 3**

**POWER PHASE WIRE TERMINAL BOX 2.0mm**

**HEAT-SINK TO BE CAST IRON/STEEL**

**SEE COIL SIZE CHART FOR SUBMOUNTING**

**MAXIMUM FORCE TO BE APPLIED TO VALVE BODY WITH CLEANANCE FOR A SLIP FIT**

**COIL SIZE: 3**

**POWER PHASE WIRE TERMINAL BOX 2.0mm**

**CERTIFIED PRODUCT**

**ASSEMBLY**

**WITHOUT THE APPROVAL OF**

**THE COMPETENT AUTHORITARY**

**CPA. T.G. 19 MAY 14**







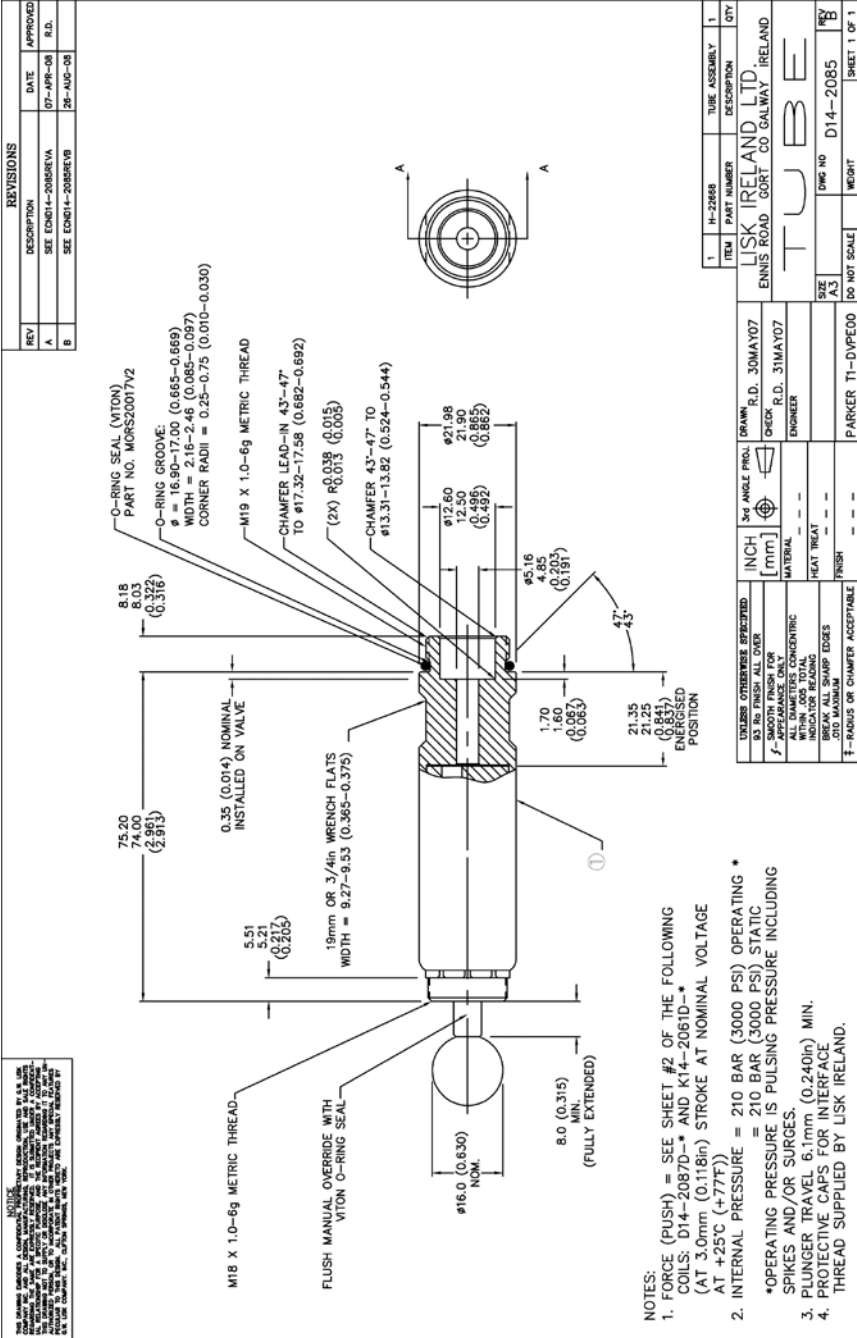

A3. Type-examination certificate – Solenoid

Certificate Number  
Baseefa02ATEX0199X



Issued 6 February 2003  
Page 1 of 3

**1 EC - TYPE EXAMINATION CERTIFICATE**

**2 Equipment or Protective System Intended for use in Potentially Explosive Atmospheres  
Directive 94/9/EC**

**3 EC – Type Examination Certificate Number :** Baseefa02ATEX0199X

**4 Equipment or protective system:** The Type D/K XX-XD-XD Solenoids

**5 Manufacturer :** G.W. Lisk Company Incorporated

**6 Address :** 2 South Street, Clifton Springs, New York, 14432, USA

**7** This equipment and any acceptable variation thereto is specified in the schedule to this certificate and the documents therein referred to.

**8** Baseefa (2001) Ltd. Notified body number 1180 in accordance with Article 9 of the Council Directive 94/9/EC of 23 March 1994, certifies that this equipment or protective system has been found to comply with the Essential Health and Safety Requirements relating to the design and construction of equipment and protective systems intended for use in potentially explosive atmospheres given in Annex II to the Directive.

The examination and test results are recorded in confidential Report No. 02(C)0465

**9** Compliance with the Essential Health and Safety Requirements has been assured by compliance with:

**EN 50014 (1997) + Amendments 1 & 2; EN 50019 (2000); EN 50028 (1987)**

except in respect of those requirements listed at item 18 of the Schedule.

**10** If the sign “X” is placed after the certificate number, it indicates that the equipment or protective system is subject to special conditions of safe use specified in the schedule to this certificate.

**11** This EC - TYPE EXAMINATION CERTIFICATE relates only to the design and construction of the specified equipment or protective system. If applicable, further requirements of this Directive apply to the manufacture and supply of this equipment or protective system.

**12** The marking of the equipment or protective system shall include the following :

**Ⓔ II 2G EEx me II T (See Schedule) -54°C ≤ T<sub>amb</sub> ≤ +40°C or -54°C ≤ T<sub>amb</sub> ≤ +60°C**

This certificate may only be reproduced in its entirety, without any change, schedule included.

Baseefa (2001) Ltd. Customer Reference No. 0435

Project File No.02/0465

This certificate is granted subject to the general terms and conditions of Baseefa (2001) Ltd. It does not necessarily indicate that the equipment may be used in particular industries or circumstances.

**R S SINCLAIR**

**DIRECTOR  
On behalf of**

**Baseefa (2001) Ltd.**

**Baseefa (2001) Ltd.**

Health and Safety Laboratory Site, Harpur Hill,  
Buxton, Derbyshire SK17 9JN

Telephone +44 (0) 1298 28255 Fax +44 (0) 1298 28216

e-mail [info@baseefa2001.biz](mailto:info@baseefa2001.biz) web site [www.baseefa2001.biz](http://www.baseefa2001.biz)

Registered in England No. 4305578 at 13 Dovedale Crescent, Buxton,  
Derbyshire, SK17 9BJ

Certificate Number  
Baseefa02ATEX0199X



Issued 6 February 2003  
Page 2 of 3

**Schedule**

**15 Description of Equipment or Protective System**

The Type D/K XX-XD-XD Solenoids comprise an encapsulated coil solenoid fitted with an increased safety terminal enclosure. Additionally the Type K solenoids are fitted with a bridge rectifier and a shunt varistor. The coil and components are encapsulated in a glass fibre filled polyester resin.

The solenoid is fitted to a core tube, which contains the solenoid armature. The core tube is provided with a mounting thread to customer specification. The solenoid is retained on the core tube by a spacer and nut.

Internal and external earth facilities are provided.

An M20 cable entry is provided for connection of the users cabling.

The solenoid is designed and rated for mounting on a specified valve body (see sheet 8 of drawing number H17423).

The Type designation represents the following information;

- i) The first character is either D for d.c. input or K for a.c. input.
- ii) The first two digits (10, 12, 13, 14, 15, 16, 17, 18 or 19) identify the diameter of the core tube in 1/16 inches.
- iii) The subsequent 1, 2, 3, or 4 digits identify information specific to the customer. Associated with these digits is the character D which indicates that the coil is an explosion protection design (EEx me).
- iv) The final group of 3 numbers signify the voltage and wattage ratings.

Both d.c. and a.c. versions are fitted with a thermal fuse rated with an operating temperature according to the applicable temperature classification as follows;

- For T6 versions a 75°C rated thermal fuse is fitted.
- For T5 versions a 90°C rated thermal fuse is fitted.
- For T4 versions a 125°C rated thermal fuse is fitted.

The solenoid coil may be wound for use with supplies of up to 250V d.c. (Type D) or 250V a.c. 50Hz or 60Hz (Type K). The maximum stabilized power dissipation for a given maximum ambient temperature and temperature classification for the solenoid mounted on a specified valve body are given in the table below.

MAXIMUM PERMITTED STABILIZED POWER (Watts)

Solenoid Type	Ambient Temperature (°C)	Power (Watts)		
		T6	T5	T4
D10, K10	40	12	18	30
	60	6	11	25
D12, K12, D13, K13, D14, K14, D15, K15	40	13	22	36
	60	4	11	30
D14, K14, D15, K15	40	16	23	39
	60	7	13	30
D16, K16, D17, K17, D18, K18, D19, K19	40	25	37	50
	60	10	22	42

Certificate Number  
Baseefa02ATEX0199X



Issued 6 February 2003  
Page 3 of 3

16 Report No. 02(C)0465

17 **Special Conditions for Safe Use**

1. The solenoid must only be mounted on a valve body which has a heat dissipation equal to or greater than the valve body shown on sheet 8 of drawing number H17423. The solenoid valve must be complete before the coil is energised.
2. The solenoid and the valve body on which it is mounted must not be thermally lagged.
3. The fluid flowing through the valve must not exceed the specified ambient temperature of 40°C or 60°C.
4. The solenoid shall be protected by fuses rated for a prospective short circuit current of at least 4000A.

18 **Essential Health and Safety Requirements**

None additional to those covered by the standards listed at item 9

19 **Drawings and Documents**

<u>Number</u>	<u>Issue</u>	<u>Date</u>	<u>Description</u>
H17423 sheet 1	A	05 Jun 01	General Arrangement
H17423 sheet 2	A	05 Jun 01	Dimensional Details
H17423 sheet 3	A	05 Jun 01	Terminal Box
H17423 sheet 4	A	05 Jun 01	Circuit Details
H17423 sheet 5	A	05 Jun 01	Coil Details
H17423 sheet 6	A	05 Jun 01	Certification Label
H17423 sheet 7	A	05 Jun 01	Voltage & Power Ratings
H17423 sheet 8	A	05 Jun 01	Heat Sink (Valve Body) Details
H17423 sheet 9	A	05 Jun 01	Encapsulant Details

Certificate Number  
Baseefa02ATEX0199X/1



Issued 8<sup>th</sup> April 2009  
Page 1 of 2

- 
- 1 **SUPPLEMENTARY EC - TYPE EXAMINATION CERTIFICATE**
  - 2 **Equipment or Protective System Intended for use in Potentially Explosive Atmospheres  
Directive 94/9/EC**
  - 3 Supplementary EC - Type Examination Certificate Number: **Baseefa02ATEX0199X/1**
  - 4 Equipment or Protective System: **The Type D/K XX-XD-XD Solenoids**
  - 5 Manufacturer: **G.W. Lisk Company Incorporated**
  - 6 Address: **2 South Street, Clifton Springs, New York 14432, USA**
  - 7 This supplementary certificate extends EC – Type Examination Certificate No. Baseefa02ATEX0199X to apply to equipment or protective systems designed and constructed in accordance with the specification set out in the Schedule of the said certificate but having any variations specified in the Schedule attached to this certificate and the documents therein referred to.

This supplementary certificate shall be held with the original certificate.

This certificate may only be reproduced in its entirety, without any change, schedule included.

Baseefa Customer Reference No. 0435

Project File No. 09/0188

This certificate is granted subject to the general terms and conditions of Baseefa. It does not necessarily indicate that the equipment may be used in particular industries or circumstances.

**Baseefa**

Rockhead Business Park, Staden Lane,  
Buxton, Derbyshire SK17 9RZ  
Telephone +44 (0) 1298 766600 Fax +44 (0) 1298 766601  
e-mail [info@baseefa.com](mailto:info@baseefa.com) web site [www.baseefa.com](http://www.baseefa.com)  
Baseefa is a trading name of Baseefa Ltd  
Registered in England No. 4305578. Registered address as above.

R S SINCLAIR  
DIRECTOR  
On behalf of  
Baseefa



Certificate Number  
 Baseefa02ATEX0199X/1



Issued 8<sup>th</sup> April 2009  
 Page 2 of 2

13

**Schedule**

14

**Certificate Number Baseefa02ATEX0199X/1**

**15 Description of the variation to the Equipment or Protective System**

**Variation 1.1**

To confirm that the equipment covered by this certificate has been reviewed against the requirements of EN 60079-0: 2006, EN 60079-7: 2007 and EN 60079-18: 2004 in respect of the differences from EN 50014: 1997 + amd. 1 & 2, EN 50019: 2000 and EN 50028: 1987 and that none of these differences in the Standard affects this equipment.

**Variation 1.2**

To permit minor design and drawing changes.

**16 Report Number**

None

**17 Special Conditions for Safe Use**

None additional to those listed previously

**18 Essential Health and Safety Requirements**

Compliance with the Essential Health and Safety Requirements is not affected by this variation.

**19 Drawings and Documents**

Number	Sheet	Issue	Date	Description
H17423	1	B	20 Feb 09	General arrangement
H17423	2	B	20 Feb 09	Dimensional detail
H17423	3	B	20 Feb 09	Terminal box
H17423	4	B	20 Feb 09	Circuit details
H17423	5	B	20 Feb 09	Coil details
H17423	6	B	20 Feb 09	Certification label
H17423	7	B	20 Feb 09	Voltage and power ratings
H17423	8	B	20 Feb 09	Heat sink (valve body) details
H17423	9	B	20 Feb 09	Encapsulant details

Certificate Number  
Baseefa02ATEX0199X/2



Issued 26 October 2012  
Page 1 of 3

1 **SUPPLEMENTARY EC - TYPE EXAMINATION CERTIFICATE**

2 **Equipment or Protective System Intended for use in Potentially Explosive Atmospheres  
Directive 94/9/EC**

3 Supplementary EC - Type **Baseefa02ATEX0199X/2**  
Examination Certificate Number:

4 Equipment or Protective System: **The Type D/K XX-XD-XD Solenoids**

5 Manufacturer: **G.W. Lisk Company Incorporated**

6 Address: **2 South Street, Clifton Springs, New York 14432, USA**

7 This supplementary certificate extends EC – Type Examination Certificate No. **Baseefa02ATEX0199X** to apply to equipment or protective systems designed and constructed in accordance with the specification set out in the Schedule of the said certificate but having any variations specified in the Schedule attached to this certificate and the documents therein referred to.

8 Item 9 of the original Certificate is replaced by "Compliance with the Essential Health and Safety Requirements has been assured by compliance with:

**EN60079-0: 2012 EN60079-7: 2007 EN60079-18: 2009**

except in respect of those requirements listed at item 18 of the Schedule."

9 The marking of the equipment has changed from the original Certificate and shall include the following:

**Ⓔ II 2 G Ex e mb T\* Gb Ta -40°C to + \*\*°C \* See schedule**

This certificate shall be held with the original certificate and may only be reproduced in its entirety, without any change, schedule included.

Baseefa Customer Reference No. **0435**

Project File No. **10/0568**

This certificate is granted subject to the general terms and conditions of Baseefa. It does not necessarily indicate that the equipment may be used in particular industries or circumstances.

**R S SINCLAIR**  
DIRECTOR  
On behalf of  
Baseefa

**Baseefa**  
Rockhead Business Park, Staden Lane,  
Buxton, Derbyshire SK17 9RZ  
Telephone +44 (0) 1298 766600 Fax +44 (0) 1298 766601  
e-mail [info@baseefa.com](mailto:info@baseefa.com) web site [www.baseefa.com](http://www.baseefa.com)  
Baseefa is a trading name of Baseefa Ltd  
Registered in England No. 4305578. Registered address as above.

Certificate Number  
 Baseefa02ATEX0199X/2



Issued 26 October 2012  
 Page 2 of 3

13

**Schedule**

14

**Certificate Number Baseefa02ATEX0199X/2**

**15 Description of the variation to the Equipment or Protective System**

**Variation 2.1**

To confirm that the equipment covered by this certificate has been reviewed against the requirements of EN 60079-0: 2012, and EN 60079-18: 2009.

**Variation 2.2**

To permit alternative ratings at 50°C ambient temperature. The maximum stabilised power for the temperature classification and ambient temperature range for each size of solenoid is indicated below.

Coil size	Ambient temperature (°C)	Maximum Stabilised Power (W)		
		T4	T5	T6
1	-40°C to +40°C	18	14	9
	-40°C to +60°C	14	8	3
2	-40°C to +40°C	21.5	15.4	10.8
	-40°C to +50°C	18.9	12.3	7.9
	-40°C to +60°C	16.4	9.3	5.1
3	-40°C to +40°C	22.2	16.4	11.4
	-40°C to +50°C	19.5	13.0	8.4
	-40°C to +60°C	16.8	9.9	5.5
4	-40°C to +40°C	34.1	21.3	15.1
	-40°C to +50°C	29.8	17.1	11.1
	-40°C to +60°C	25.6	13.1	7.3

The table above supersedes the previously permitted wattages.

**Variation 2.3**

Deletion of the use of a varistor.

**Variation 2.4**

The use of thermal fuses to be optional.

**16 Report Number**

Baseefa certification report 10(C)0568.

**17 Specific Conditions of Use**

The solenoids shall be protected by fuses rated for a prospective short circuit current of at least 1500A.

**18 Essential Health and Safety Requirements**

Compliance with the Essential Health and Safety Requirements is not affected by this variation.

Certificate Number  
Baseefa02ATEX0199X/2



Issued 26 October 2012  
Page 3 of 3

## 19 Drawings and Documents

Number	Sheet	Issue	Date	Description
H17423	1	C	14 Sept 2012	General Assembly
H17423	2	C	14 Sept 2012	General Assembly and sizes
H17423	3	C	14 Sept 2012	Terminal Box Details
H17423	4	C	14 Sept 2012	Internal Components and Wiring Details
H17423	5	C	14 Sept 2012	Winding Details
H17423	6	C	14 Sept 2012	Marking Details
H17423	7	C	14 Sept 2012	Power Details
H17423	8	C	14 Sept 2012	Valve and Subplate details
H17423	9	C	14 Sept 2012	Compound Details

Certificate Number  
Baseefa02ATEX0199X/3



Issued 16 May 2014  
Page 1 of 2

- 1 SUPPLEMENTARY EC - TYPE EXAMINATION CERTIFICATE**
- 2 Equipment or Protective System Intended for use in Potentially Explosive Atmospheres  
Directive 94/9/EC**
- 3 Supplementary EC - Type Examination Certificate Number: **Baseefa02ATEX0199X/3**
- 4 Equipment or Protective System: **Type D/KXX-XXXX-XX Solenoids**
- 5 Manufacturer: **G.W. Lisk Company Incorporated**
- 6 Address: **2 South Street, Clifton Springs, New York 14432, USA**
- 7 This supplementary certificate extends EC – Type Examination Certificate No. **Baseefa02ATEX0199X** to apply to equipment or protective systems designed and constructed in accordance with the specification set out in the Schedule of the said certificate but having any variations specified in the Schedule attached to this certificate and the documents therein referred to.

This supplementary certificate shall be held with the original certificate.

Baseefa Customer Reference No. **0435**

Project File No. **13/0686**

This document is issued by the Company subject to its General Conditions for Certification Services accessible at <http://www.sgs.com/en/Terms-and-Conditions.aspx> and the Supplementary Terms and Conditions accessible at <http://www.baseefa.com/terms-and-conditions.asp>. Attention is drawn to the limitation of liability, indemnification and jurisdiction issues defined therein. Any holder of this document is advised that information contained herein reflects the Company's findings at the time of its intervention only and within the limits of Client's instructions, if any. It does not necessarily indicate that the equipment may be used in particular industries or circumstances. The Company's sole responsibility is to its Client and this document does not exonerate parties to a transaction from exercising all their rights and obligations under the transaction documents. This document cannot be reproduced except in full, schedule included, without prior written approval of the Company. Any unauthorized alteration, forgery or falsification of the content or appearance of this document is unlawful and offenders may be prosecuted to the fullest extent of the law.

**SGS Baseefa Limited**

Rockhead Business Park, Staden Lane,  
Buxton, Derbyshire SK17 9RZ

Telephone +44 (0) 1298 766600 Fax +44 (0) 1298 766601  
e-mail [info@baseefa.com](mailto:info@baseefa.com) web site [www.baseefa.com](http://www.baseefa.com)

Registered in England No. 4305578.

Registered address: Rossmore Business Park, Ellesmere Port, Cheshire, CH65 3EN

**R S SINCLAIR**  
GENERAL MANAGER

On behalf of SGS Baseefa Limited

Certificate Number  
Baseefa02ATEX0199X/3



Issued 16 May 2014  
Page 2 of 2

13

## Schedule

14

**Certificate Number Baseefa02ATEX0199X/3**

15 **Description of the variation to the Equipment or Protective System**

### Variation 3.1

To permit the option of an alternative terminal enclosure with two cable entries.

### Variation 3.2

To note minor modifications and rewording of the Specific Conditions of Use.

16 **Report Number**

GB/BAS/ExTR13.0206/00.

17 **Specific Conditions of Use**

1 The solenoid must only be used on valve sizes with heat dissipation specified by the manufacturer of the solenoid in the instructions. The solenoid must be completely assembled with the valve before the solenoid is energised.

2 The solenoid and the valve on which it is mounted must not be thermally lagged.

3 The fluid flowing through the valve must not exceed the specified ambient temperature.

4 The solenoid shall be protected by a fuse rated for a prospective short circuit current of at least 1500A.

18 **Essential Health and Safety Requirements**

Compliance with the Essential Health and Safety Requirements is not affected by this variation.

19 **Drawings and Documents**

Number	Sheet	Issue	Date	Description
H17423	1	D	23.Apr.14	General Assembly
H17423	2	D	23.Apr.14	General Assembly and Sizes
H17423	3	D	23.Apr.14	Terminal Box Details
H17423	4	D	23.Apr.14	Internal Components and Wiring Details
H17423	5	D	23.Apr.14	Winding Details
H17423	6	D	23.Apr.14	Marking Details
H17423	7	D	23.Apr.14	Power Details
H17423	8	D	23.Apr.14	Valve and Subplate Details
H17423	9	D	23.Apr.14	Compound Details
H17423	10	D	23.Apr.14	Alternative Terminal Enclosure



# IECEx Certificate of Conformity

## INTERNATIONAL ELECTROTECHNICAL COMMISSION IEC Certification Scheme for Explosive Atmospheres

for rules and details of the IECEx Scheme visit [www.iecex.com](http://www.iecex.com)

Certificate No.:	IECEx BAS 13.0093X	Issue No: 0	Certificate history: Issue No. 0 (2014-05-16)
Status:	Current	Page 1 of 3	
Date of Issue:	2014-05-16		
Applicant:	G.W. Lisk Company Incorporated 2 South Street Clifton Springs New York 14432 United States of America		
Electrical Apparatus: Optional accessory:	Type D/KXX-XXXX-XX solenoids		
Type of Protection:	Increased safety and Encapsulation		
Marking:	Ex e mb IIC T* Gb Ta -40°C to + ***°C		
Approved for issue on behalf of the IECEx Certification Body:	R S Sinclair		
Position:	General Manager		
Signature: (for printed version)	_____		
Date:	_____		

1. This certificate and schedule may only be reproduced in full.
2. This certificate is not transferable and remains the property of the issuing body.
3. The Status and authenticity of this certificate may be verified by visiting the Official IECEx Website.

Certificate issued by:

SGS Baseefa Limited  
Rockhead Business Park  
Staden Lane  
Buxton  
Derbyshire  
SK17 9RZ  
United Kingdom





# IECEx Certificate of Conformity

Certificate No: IECEx BAS 13.0093X Issue No: 0  
 Date of Issue: 2014-05-16 Page 2 of 3  
 Manufacturer: G.W. Lisk Company Incorporated  
 2 South Street  
 Clifton Springs  
 New York 14432  
 United States of America

Additional Manufacturing location(s):  
**Lisk Ireland Manufacturing Limited**  
 Ennis Road  
 Gort  
 County Galway  
 Ireland

This certificate is issued as verification that a sample(s), representative of production, was assessed and tested and found to comply with the IEC Standard list below and that the manufacturer's quality system, relating to the Ex products covered by this certificate, was assessed and found to comply with the IECEx Quality system requirements. This certificate is granted subject to the conditions as set out in IECEx Scheme Rules, IECEx 02 and Operational Documents as amended.

**STANDARDS:**

The electrical apparatus and any acceptable variations to it specified in the schedule of this certificate and the identified documents, was found to comply with the following standards:

- IEC 60079-0 : 2011 Explosive atmospheres - Part 0: General requirements  
Edition:6.0
- IEC 60079-18 : 2009 Explosive atmospheres Part 18: Equipment protection by encapsulation "m"  
Edition:3
- IEC 60079-7 : 2006-07 Explosive atmospheres - Part 7: Equipment protection by increased safety "e"  
Edition:4

*This Certificate does not indicate compliance with electrical safety and performance requirements other than those expressly included in the Standards listed above.*

**TEST & ASSESSMENT REPORTS:**

*A sample(s) of the equipment listed has successfully met the examination and test requirements as recorded in*

Test Report:

GB/BAS/ExTR13.0206/00

Quality Assessment Report:

GB/BAS/QAR11.0009/02 GB/BAS/QAR14.0006/00





## IECEx Certificate of Conformity

Certificate No: IECEX BAS 13.0093X

Issue No: 0

Date of Issue: 2014-05-16

Page 3 of 3

**Schedule**

**EQUIPMENT:**

*Equipment and systems covered by this certificate are as follows:*

The Type D/KXX-XXXX-XX solenoids comprise an encapsulated solenoid coil and an increased safety terminal enclosure. The solenoid is fitted to a core tube which contains the solenoid armature. The core tube is provided with a mounting thread to customer specification. The solenoid is retained on the core tube by a spacer and nut. A bridge rectifier or four diodes and a thermal cut-out may optionally be provided within the encapsulation.

The stainless steel terminal enclosure contains a type MK 6/2 2 way terminal block to IECE05.0037U, and an internal earth facility. The enclosure has a cover with a gasket and up to two M20 cable entries.

The solenoids are available in three sizes. The coils are rated 6-250Vdc, 24-250Vac, and have a maximum stabilised wattage for the temperature classification and ambient temperature range for each size of solenoid as indicated below.

Solenoid size	Ambient temperature range	Maximum Power (W)		
		T4	T5	T6
2	-40°C to +40°C	21.5	15.4	10.8
	-40°C to +50°C	18.9	12.3	7.9
	-40°C to +60°C	16.4	9.3	5.1
3	-40°C to +40°C	22.2	16.4	11.4
	-40°C to +50°C	19.5	13.0	8.4
	-40°C to +60°C	16.8	9.9	5.5
4	-40°C to +40°C	34.1	21.3	15.1
	-40°C to +50°C	29.8	17.1	11.1
	-40°C to +60°C	25.6	13.1	7.3

**CONDITIONS OF CERTIFICATION: YES as shown below:**

- 1 The solenoid must only be used on valve sizes with heat dissipation specified by the manufacturer of the solenoid in the instructions. The solenoid must be completely assembled with the valve before the solenoid is energised.
- 2 The solenoid and the valve on which it is mounted must not be thermally lagged.
- 3 The fluid flowing through the valve must not exceed the specified ambient temperature.
- 4 The solenoid shall be protected by a fuse rated for a prospective short circuit current of at least 1500A.



Issued: 16<sup>th</sup> May 2014  
Page 1 of 1

**Schedule to ATEX Quality Assurance Notification / IECEx Quality Assessment Report**  
**Number: 3558**  
**Issued to: Lisk Ireland Ltd**

Products for which the company manufactures the product, but for which the following company controls the design:		
G.W. Lisk Company Inc - 0435		
Product Type Designation	Type Examination Certificate Number (Including ATEX)	IECEX Certificate of Conformity Number
Product category - Ex me		
The Type D/K XX-XD-XD Solenoids	Baseefa02ATEX0199X	IECEX BAS 13.0093X

Cert - Qaschedule -- Issue 7 - February 2008

A4. Declaration of conformity - Solenoid



LISK IRELAND LIMITED



Ennis Road, Gort, Co. Galway, Ireland. Telephone: (353) 91-631711, 631101 Fax: (353) 91-633011

MANUFACTURERS STATEMENT

In Relation to:

INGRESS PROTECTION (IP) RATING OF



SOLENOIDS RATED FOR USE IN HAZARDOUS LOCATIONS

SOLENOIDS OF THE FOLLOWING DESIGNATION ARE CERTIFIED TO

HAVE AN

INGRESS PROTECTION RATING OF

**IP66 in accordance with BS5490**

D10-\*\*\*\*D-\*, D12-\*\*\*\*D-\*, D14-\*\*\*\*D-\*, D15-\*\*\*\*D-\*,  
D16-\*\*\*\*D-\*, D19-\*\*\*\*D-\*,  
&  
K10-\*\*\*\*D-\*, K12-\*\*\*\*D-\*, K14-\*\*\*\*D-\*, K15-\*\*\*\*D-\*,  
K16-\*\*\*\*D-\*, K19-\*\*\*\*D-\*,

Engineering Manager.

March 2010.

## A5. Mounting instruction cable gland

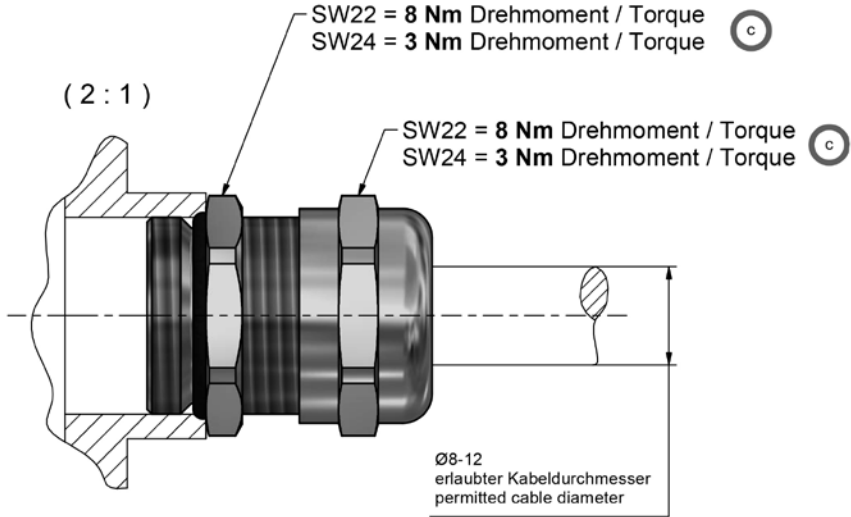

Der Nutzer muss beim elektrischen Anschließen des Ventils sicherstellen, dass die oben aufgeführten Drehmomente eingehalten werden.  
Auslieferungszustand der Kabeldurchführung:

entweder am Ventil handfest eingeschraubt oder in Tüte beigelegt.

- (C) Bei der Demontage der Hutmutter muss der eingeschraubte Zwischenstutzen, mit einem passendem Werkzeug, festgehalten werden.

When connecting the valve electrically, the user must ensure that the torques listed above are observed.

Delivery condition of the cable entry:

- (C) either screwed hand-tight on the valve or enclosed in a bag.
- (C) When dismantling the dome nut, the screwed-in gland body must be held in place with a suitable tool.

Supersedes drawing		Material		Raw part		Change-Nr. 01-JUL-2021_BJ		
ISO/R 128 A		Property of PARKER HANNIFIN Not to be used; disclosed; or copied without its written consent. To be returned with all copies upon completion of authorized use.				Prod. Stat.: PR= Series Release EX = Prototype; No Series Release		
		= Function critical dimension		Originator Broeckmann	Date 24.08.2010	Parker Hannifin Industrial Systems Division Europe Gutenbergstr. 38 41564 Kaarst (Germany)		
Geometrical tolerancing acc. to DIN ISO 1101		1st. Approver Tschetschko		Date 24.08.2010				
Surface finish acc. to DIN ISO 1302		Scale 2:1		Units mm				
General tolerance acc. to DIN ISO 2768-m K		Title <b>ATEX Kabelverschraubung / Cable gland</b>						
Nominal size range (mm)	0,5 to 6	>6 to 30	>30 to 120	>120 to 400	>400 to 1000	>1000 to 2000		
Tolerance	±0,1	±0,2	±0,3	±0,5	±0,8	±1,2		
Sheet		Size		Drawing number		Rev. Prod. Stat.		
1 / 2		A4		5005113		C PR		